

MDT 128

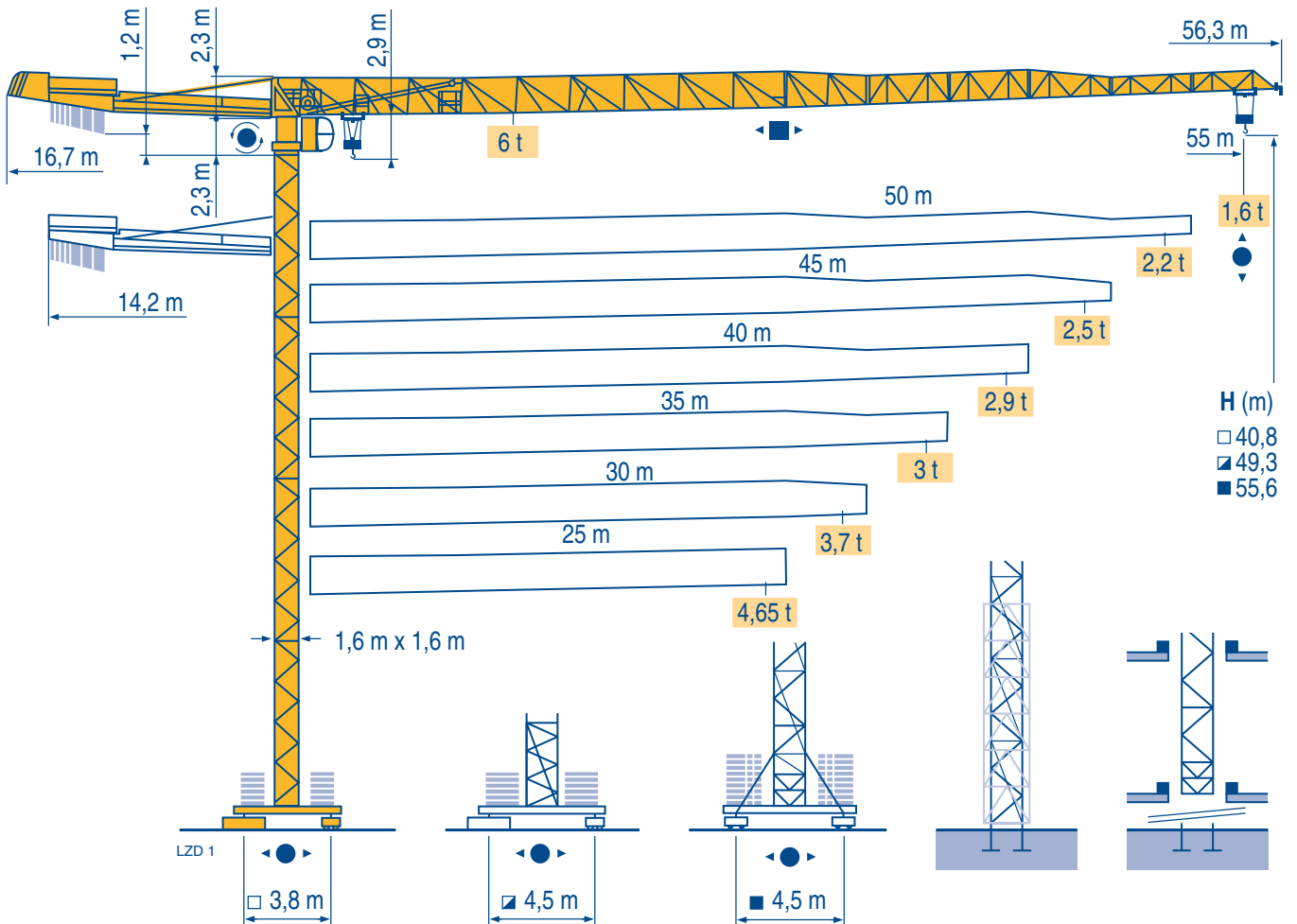

City Topless

CE FEM 1.001-A3

Mat / Réactions City 1,6 m

Maste / Eckdrücke

Masts / Reactions

Mástil / Reacciones

Torre / Reazioni

Tramo / Reações

LZD 1

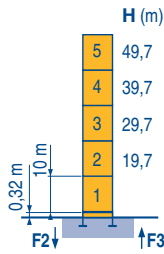

P 41 A	
F2	● 103 t
	■ 133 t
F3	● 77 t
	■ 110 t
	▲ 34 t

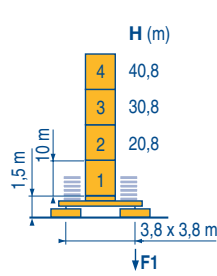

ZC 4030	
F1	● 62 t
	■ 65 t
	▲ 38 t

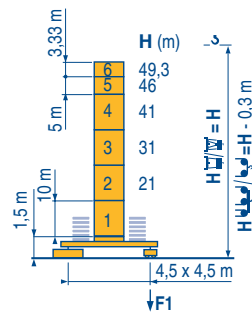

ZD 4230	
F1	● 66 t
	■ 81 t
	▲ 42 t

ZC 4030 - ZD 4230

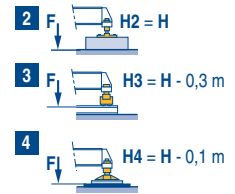

Télescopable 1,6 m
Teleskopierbar 1,6 m
Telescopico 1,6 m
Telescopico 1,6 m
Telescopagem 1,6 m

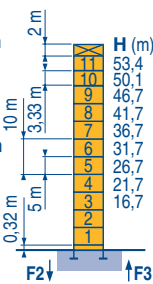

P 41 A	
F2	● 116 t
	■ 166 t
F3	● 84 t
	■ 137 t
	▲ 46 t

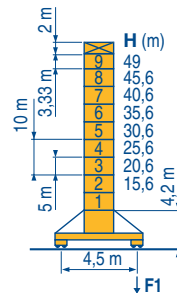

S 40 A	
F1	● 71 t
	■ 88 t
	▲ 51 t

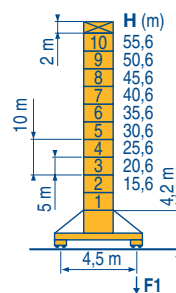

S 41 A	
F1	● 85 t
	■ 113 t
	▲ 54 t

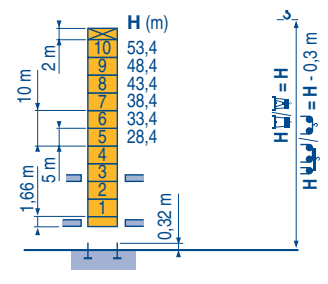

B 43 A	
	●

Télescopage sur dalles

Kletterkrane im Gebäude

Climbing crane

Telescopage gruas trepadoras

Gru in cavedio

Telescopagem sobre lajes

LZD 1

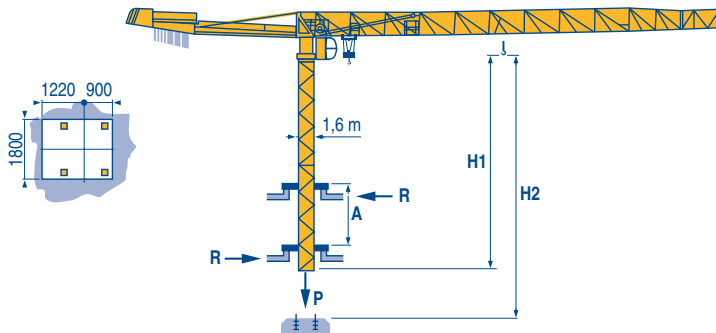

B 43 A

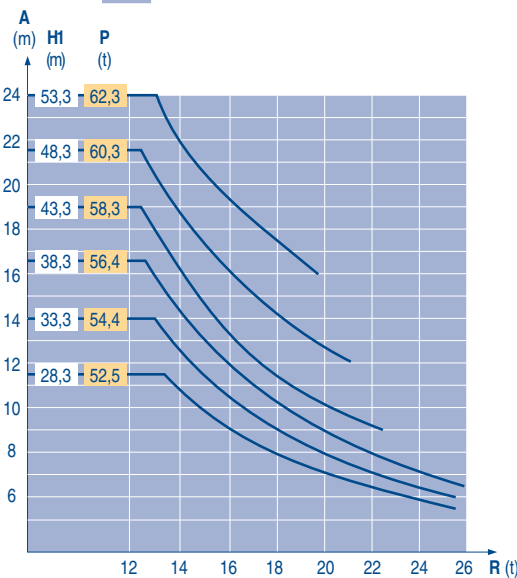

City Topless

MDT 128



F

Réactions en service
Réactions hors service



A vide sans lest (ni train de transport) avec flèche et hauteur maximum.

D

Reaktionskräfte in Betrieb
Reaktionskräfte außer Betrieb

Ohne Last, Ballast (und Transportachse), mit Maximalausleger und Maximalhöhe.

GB

Reactions in service
Reactions out of service

Without load, ballast (or transport axes), with maximum jib and maximum height.

E

Reacciones en servicio
Reacciones fuera de servicio

Sin carga, sin lastre, (ni tren de transporte), flecha y altura máxima.

I

Reazioni in servizio
Reazioni fuori servizio

A vuoto, senza zavorra (ne assali di trasporto) con braccio massimo e altezza massima.

P

Reações em serviço
Reações fora de serviço

Sem carga (nem trem de transporte)- sem lastro com lança e altura máximas.

Curbes de charges

Lastkurven

Load diagrams

Curvas de cargas

Curve di carico

Curva de cargas

LZD 1

55 m	3,1 ▶	17,3	20	22	25	27	30,1	33,2	35	37	40	42	45	47	50	52	55 m
▲▲▲		6	5	4,5	3,8	3,5	3	3	2,8	2,65	2,4	2,25	2,05	1,95	1,8	1,7	1,6 t
50 m	3,1 ▶	20	22	25	27	30	32	35,1	38,7	40	42	45	47	50 m			
▲▲▲		6	5,4	4,6	4,2	3,7	3,4	3	3	2,9	2,7	2,5	2,35	2,2 t			
45 m	3,1 ▶	20	22	25	27	30	32	35	38,7	40	42	45 m					
▲▲▲		6	5,4	4,6	4,2	3,7	3,4	3	3	2,9	2,7	2,5 t					
40 m	3,1 ▶	20,1	22	25	27	30	32	35,2	38,9	40 m							
▲▲▲		6	5,4	4,6	4,2	3,7	3,4	3	3	2,9 t							
35 m	3,1 ▶	20,1	22	25	27	30	32	35 m									
▲▲▲		6	5,4	4,6	4,2	3,7	3,4	3 t									
30 m	3,1 ▶	20,2	22	25	27	30 m											
▲▲▲		6	5,4	4,6	4,2	3,7 t											
25 m	3,1 ▶	20,2	22	25 m													
▲▲▲		6	5,4	4,65 t													

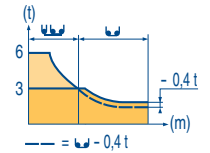

55 m	2,4 ▶	17,5	20	22	25	27	30	31,2	31,7	35	37	40	42	45	47	50	52	55 m
▲▲▲		6	5,1	4,6	3,9	3,6	3,2	3	3	2,65	2,45	2,25	2,1	1,9	1,8	1,65	1,55	1,45 t
50 m	2,4 ▶	20,4	22	25	27	30	32	35	36,4	37	40	42	45	47	50 m			
▲▲▲		6	5,5	4,7	4,3	3,8	3,5	3,2	3	3	2,75	2,55	2,35	2,2	2,05 t			
45 m	2,4 ▶	20,4	22	25	27	30	32	35	36,4	37	40	42	45 m					
▲▲▲		6	5,5	4,7	4,3	3,8	3,5	3,2	3	3	2,75	2,55	2,35 t					
40 m	2,4 ▶	20,6	22	25	27	30	32	35	36,7	37,3	40 m							
▲▲▲		6	5,5	4,8	4,4	3,8	3,6	3,2	3	3	2,75 t							
35 m	2,4 ▶	20,6	22	25	27	30	32	35 m										
▲▲▲		6	5,6	4,8	4,4	3,9	3,6	3,2 t										
30 m	2,4 ▶	20,6	22	25	27	30 m												
▲▲▲		6	5,6	4,8	4,4	3,8 t												
25 m	2,4 ▶	20,6	22	25 m														
▲▲▲		6	5,6	4,8 t														

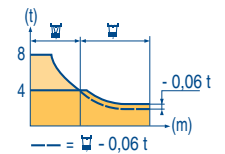

Lest de contre-flèche

Gegenauslegerballast

Counter-jib ballast

Lastre de contra flecha

Contrappeso

Lastros da contra lança

LZD 1

		1 100 kg - 3 600 kg
▲▲▲		(kg)
55 m	16,7 m	12 700
50 m	14,2 m	12 700
45 m	14,2 m	11 600
40 m	14,2 m	10 500
35 m	14,2 m	9 400
30 m	14,2 m	9 400
25 m	14,2 m	8 300

Lest de base

Grundballast

Base ballast

Lastre de base

Zavorra di base

Lastros da base

LZD 1

☑ 1,6 m	ZC 4030 ◀●▶	H (m)	40,8	30,8	20,8	10,8					
		▲ (t)	70	65	60	55					
☑ 1,6 m	ZD 4230 ◀●▶	H (m)	49,3	46	41	31	21	11			
		▲ (t)	80	75	60	45	45	45			
☑ 1,6 m	S 40 A ◀●▶	H (m)	49	45,6	40,6	35,6	30,6	25,6	20,6	15,6	
		▲ (t)	84	72	54	42	42	42	36	36	
☑ 1,6 m	S 41 A ◀●▶	H (m)	55,6	50,6	45,6	40,6	35,6	30,6	25,6	20,6	15,6
		▲ (t)	114	96	72	54	42	42	42	36	36

City Topless

MDT 128



A	F	D	GB	E	I	P
Distance entre cadres	Abstand zwischen den Rahmen	Distance between collars	Distancia entra marcos	Distanza fra i telai	Distância entre quadros	
H1	Hauteur grue	Kranhöhe	Crane height	Altura grúa	Altezza gru	Altura da grua
P	Poids de la grue(en service)	Krangewicht (in Betrieb)	Crane weight (in service)	Peso de la grúa (en servicio)	Peso della gru (in servizio)	Peso da grua (em serviço)
R	Réaction horizontale	Horizontalkräfte	Horizontal reaction	Reaccion horizontal	Reazione orizzontale	Reacção horizontal
	Voir télescopage sur dalles	Siehe Kletterkrane im Gebäude	See climbing crane	Veja grua trepadora	Consultare gru in cavedio	Ver telescopagem sobre lages

Mécanismes
Antriebe
Mechanisms
Mecanismos
Meccanismi
Mecanismos

LZD 3

		↕						↕↕						ch - PS hp	kW												
↕	25 LVF 15 Optima	m/min	3,2	→	8,6	→	30	→	40	→	52	→	70	1,6	→	4,3	→	15	→	20	→	26	→	35	25	18	260 m
	33 LVF 15 Optima	t	3	→	3	→	3	→	2,25	→	1,5	→	0,75	6	→	6	→	6	→	4,5	→	3	→	1,5	30	22	260 m
↔	7 DVF 4	m/min													0	→	79	6,5	4,8								
↻	RVF 152 Optima +	tr/min U/min rpm													0	→	0,8	2 x 5,5	2 x 4								
ZC 4030 ↔	RT 224	m/min													25	2 x 4	2 x 2,9										
ZD 4230 ↔	RT 324	m/min													12,5 - 25	2 x 7	2 x 5,2										
S 40 A ↔	RT 324 R ≥ 10 m	m/min													12,5 - 25	2 x 7	2 x 5,2										
S 41 A ↔	RT 443 A1 2V R ≥ 10 m	m/min													15 - 30	4 x 5	4 x 3,7										
CEI 38		IEC 38		kVA																							
400 V (+6% -10%) 50 Hz				25 LVF : 40 kVA 33 LVF : 50 kVA						2000 / 14																	

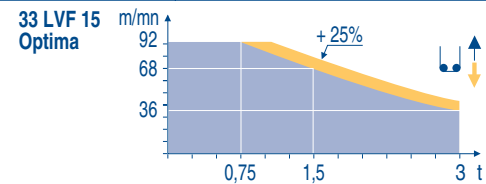
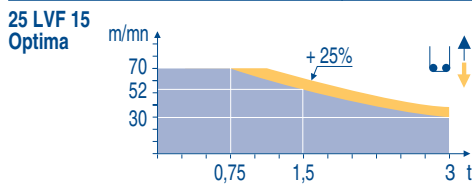

	F	D	GB	E	I	P
	Levage	Heben	Hoisting	Elevación	Sollevamento	Elevação
	Distribution	Katzfahren	Trolleying	Distribución	Distribuzione	Distribuição
	Orientation	Schwenken	Slewing	Orientación	Rotazione	Rotação
	Translation	Kranfahren	Travelling	Traslación	Traslazione	Translação
	Conforme aux directives CEE sur le niveau acoustique	Gemäss EWG-Richtlinien für den Schall-Leistungspegel	In compliance with the EEC Instructions on noise level	Conforme con las directivas CEE sobre el nivel acústico	Conforme alle direttive CEE sul livello acustico	Conforme as directivas CEE sobre o nível acústico

Document commercial non contractuel. Pour toute information technique se référer à la notice correspondante

Unverbindliches Vertriebsdokument. Für technische Informationen, siehe die entsprechenden Anweisungen.

This commercial document is not legally binding. For any technical information, please refer to the corresponding instructions.

Documento comercial no contractual. Para cualquier información técnica, ver la noticia correspondiente.

Documento commerciale non vincolante, per tutte le informazioni tecniche fare riferimento al catalogo istruzioni

Documento comercial não vinculante. Para qualquer informação técnica complementar consultar as respectivas instruções



18, rue de Charbonnières - B.P.173
69132 ECULLY Cedex - France

Tél. : (33) 4 72 18 20 20
Fax : (33) 4 72 18 20 00
www.manitowoccrane.com www.potain.com



Americas
Tel: +1 920 683 6322
Tel: +1 717 597 8121

Europe - Middle East - Africa
Tel : +(33) 4 72 81 50 00
Tel : +(44) 191 565 6281

Asia - Pacific
Tel: +(65) 6861 7133
Fax: +(65) 6862 4142

www.manitowoccrane.com

City Topless MDT 128
Réf. 2003 48 LZD 3

Copyright.Reproduction interdite © POTAIN 2003

Réalisation Sedoc